

## **Study for monitoring of the insulation stator winding of the hydro generators using a data acquisition system**

Mihaela Molnar, Eugen Răduca\*

*The paper presents a study for a system for data acquisition in order to monitor online the state of the insulation stator winding of hydro generators, using the LabVIEW graphical programming language. The data acquisition system allows the acquisition of the quantities of interest in the process and at the same time, through it, the creation of a strong database for the current state of the hydro generator insulation.*

**Keywords:** *insulation, stator, data acquisition, LabVIEW*

### **1. Introduction**

During operation, the insulation of the stator winding of the wind turbines is subjected to electrical, thermal, mechanical and environmental stresses. Due to these stresses, the properties of the insulation change and, over a longer period of time, the physical characteristics - including the electrical ones - worsen. [1].

The term "insulation aging" means the gradual degradation (deterioration) of insulating properties. This aging process will lead to a worsening of the reliability of the electrical insulation, characterized by a rate of failure over time.

The causes of the aging of the insulation consist in the irreversible physical-chemical changes in the electrical insulating materials, due to the exploitation demands and, first of all, due to their thermal stresses.

The aging of the insulation is predetermined, first of all, by the temperature of the insulation, due to the facilitation of the development conditions and the increase of the speed of the chemical reactions in the material at high temperature. The higher the temperatures of the electrical insulating materials, the more molecules enter the chemical reaction, thereby intensifying the aging phenomena of the insulation [5].

The influence of the electric field intensity on the aging of the insulation compared to the temperature is significantly lower, but noticeable in certain materials.

The intensity of the electric field directly influences, in other cases indirectly, the aging of the insulation, through the chemical and mechanical effect of the local non-destructive discharges (from or on the surface of the electrical insulating materials) [6].

## 2. System for the acquisition of quantities of interest in the stator windings of hydro generators in the LabVIEW graphic programming language

### 2.1. Block diagram of the assembly

The block diagram of the production platform - data acquisition system assembly is presented in figure 1.

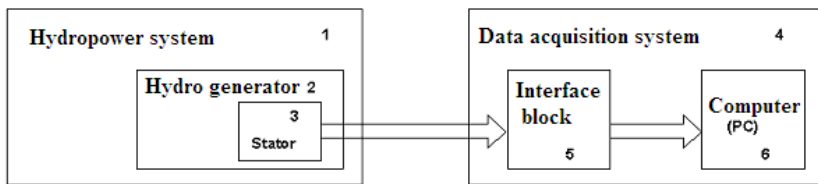

**Figure 1.** The block diagram of the production platform - data acquisition system assembly

The production platform is represented by the hydropower system 1, in which the hydrogen generator 2 constitutes a subsystem thereof. The component directly targeted for monitoring is its stator.

For some of the stator parameters monitoring is possible (temperature at various points, working voltage), but others can not be known permanently (insulation thickness at each coil) but only when the machine is overhauled [4].

The data acquisition system - 5 - allows the continuous collection and storage of parameters that can be measured directly and continuously.

### 2.2. The structure of the system

The sizes of interest at the stator windings of the hydro generators are:

- stator winding temperature
- the current in the stator
- electrical voltage of the stator

They are purchased with the following main purposes:

- their monitoring;
- knowledge and processing of information during the operation of hydro generators;

- knowledge and processing of information in hydro generator tests;
- control and regulation of the correct operation of the hydro generators.

Figure 2 shows the structure of a data acquisition system with an analog input signal [3].

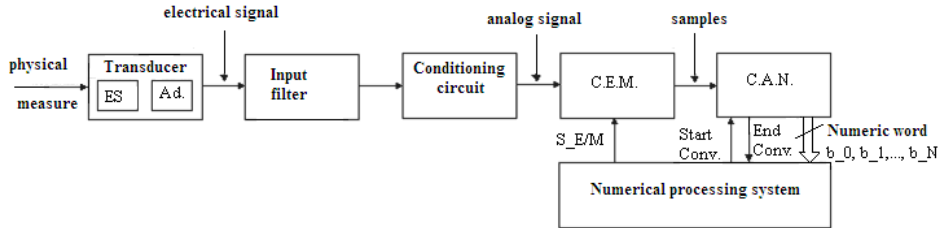

**Figure 2.** The structure of a data acquisition system with an analog input signal

Where:

- ES – sensitive element;
- Ad. – adapter;
- C.E.M. – sampling and storage circuit;
- C.A.N. – digital to analog converter
- Conv. – conversion

This data acquisition system was used to monitor the quantities of interest in the stator windings of the hydro generators.

### 2.3. Presentation of the program in the graphic programming language LabVIEW

Figure 3 shows the application we called MWM-AQ-DW1.VI designed built for data acquisition from stator [7].

The program is of graphic type, made in LabVIEW [2] and has two interdependent components figure 3.a - Front panel and figure 3.b - Block diagram.

The operation on the program is done from the computer, acting directly on the front panel.

From the block diagram it can be seen that the program was designed for the simultaneous analysis of data in simple precision, on 3 channels, marked channel 0, channel 1 and channel 2.

The DI Mult PI command (shown in figure 3.b) is a strong one, being possible the choice by the operator from the front panel (figure 3.a) of the total number of samples purchased, as well as the number of samples purchased in the unit of time.

The accuracy and speed of sampling are primarily conditioned by the acquisition plate used [8]. An NI LabPC + type acquisition board was used.

The board proved to be suitable for the proposed purpose, namely to monitor the insulation temperature as well as the voltage and current in the stator.

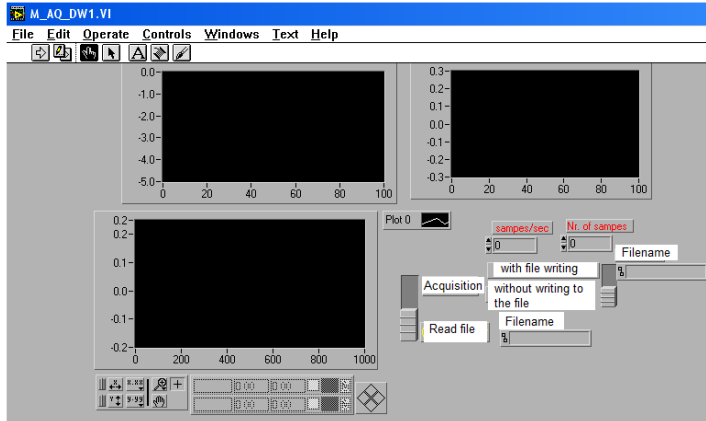

a)

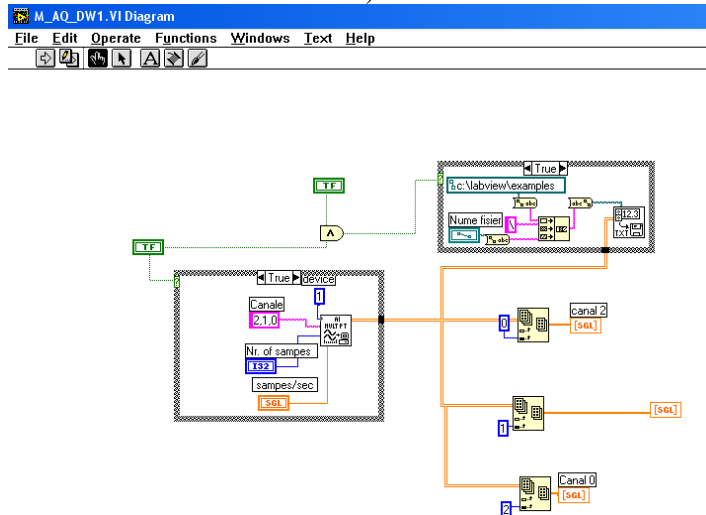

b)

**Figure 3.** Program for the acquisition of data of interest sizes:

a) Front panel; b) Block diagram

The front panel contains three plot indicator instruments through which each of the three measured sizes of interest can be viewed at the same time and can be stored or not in a file (through the "write acquisition" and "acquisition selections without write in the file").

Acquisition sizes can be read later at any time from the file in which they were stored ("read file").

Another problem that had to be solved was the transmission of data from the file to another peripheral of the PC where the acquisition was made. For this purpose, the program called D\_EX\_D2K.VI was designed, whose front panel is given in figure 4. a, and the associated block diagram in figure 4. b.

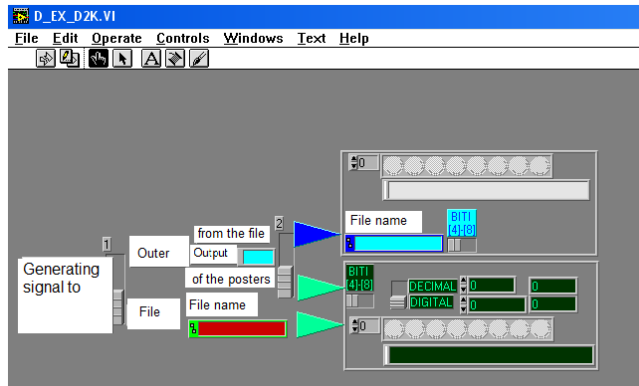

a)

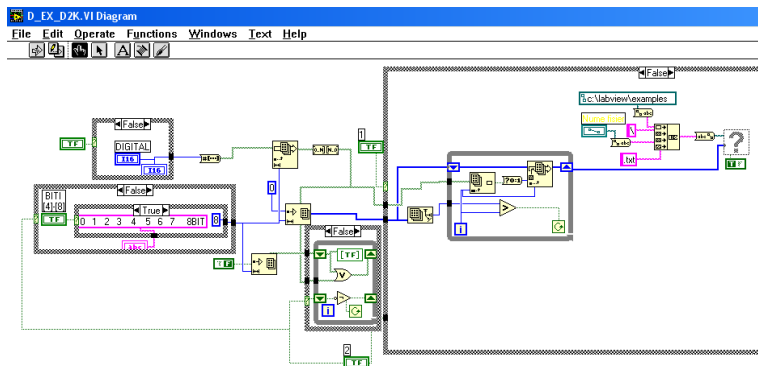

b)

**Figure 4.** Data transmission program between the acquisition system and the monitoring system: a) Front panel; b) Block diagram

Through this program the data acquired in the original file can be transmitted to another file via the "Generate signal to file" button. The transmission can be done externally, through the parallel port of the PC, or in another file in the PC.

### 3. Conclusions

This program is the development of a program that the authors used to measure electrical quantities.

The design and implementation of a monitoring system for determining the state of the insulation has led to the possibility of preventing the destruction of the hydro generator as a result of the destruction of the insulation during its operation.

The data acquisition system allows the acquisition of the measured sizes of interest in the process and at the same time, through it, the creation of a strong database for the current state of the hydro generator insulation.

### References

- [1] Boulter E.A., Stone G.C., Historical development of rotor and stator winding insulation materials and systems, *IEEE Electrical Insulation Magazine*, 20(31), pp. 25–39, 2004.
- [2] Bujoreanu C, *LABVIEW, prietenul nostru*, Iași, 2015.  
<https://mec.tuiasi.ro/diverse/labview.pdf>
- [3] Ciascai I., *Sisteme de achiziție de date pentru calculatoare personale*, Editura Albastră, Cluj-Napoca, 1998.
- [4] David V, *Masurarea marimilor electrice și neelectrice*, Universitatea Tehnică „Gh Asachi” Iași, 2015.
- [5] Drăgănescu O., *Încercările mașinilor electrice rotative*, Editura Tehnică, București, 1987.
- [6] Horvath T., ș.a., *Încercarea izolației electrice*, Editura Tehnică, București, 1982.
- [7] Răduca M., *Contribuții la identificarea, modelarea și simularea sistemelor de izolație ale hidrogenatoarelor*, Editura Politehnica, Timișoara, 2007.
- [8] Selisteanu D., Petre E., *Instrumentație virtuală. Aplicații de prelucrare numerică a semnalelor*, Editura MATRIXROM, București, 2010.

*Addresses:*

- Assist. Prof. Dr. Eng. Mihaela Molnar, Babeș-Bolyai University, Faculty of Engineering, nr. 1-4, 320085, Reșița, [m.molnar@uem.ro](mailto:m.molnar@uem.ro)
- Prof. Dr. Eng. Eugen Răduca, Babeș-Bolyai University, Faculty of Engineering, Piața Traian Vuia, nr. 1-4, 320085, Reșița, [e.raduca@uem.ro](mailto:e.raduca@uem.ro)  
(\* corresponding author)